



Installation manual
Central vacuum cleaning system
03/2010 - V 1.0 - ENG



Elek Trends Productions nv
Rue des Bengalis 4 | B - 7700 Moeskroen
Tel. +32 (0)56 48 15 90 | Fax +32 (0)56 48 15 91 | info@elek-trends.be



INDEX

1. Safety precautions,	p5
2. Technical data sheet	p6
3. Mounting,	p7
Millennium,	p7
4. Installation instructions,	p8
a. Position of the vacuum unit,	p8
b. Position of the vacuum sockets,	p8
c. Planning the pipe system,	p8
d. Example showing where to fit vacuum sockets,	p11
e. Understanding,	p12
f. The principles,	p12
g. The pipework,	p12
h. The pipe fittings,	p12
i. The pipe work,	p13
j. The electrical supply (12V),	p13
k. Millennium range of PVC vacuum sockets	p16
l. Range of Stainless steel vacuum sockets	p16
m. Installation materials,	p17
5. General notes,	p18
Vacuum sockets,	p18
Internal pipe work,	p18
External pipe work,	p18
Conclusion	p18
6. Use and maintenance	p20
7. Important safety instructions,	p21

I. SAFETY PRECAUTIONS

For the correct and safe installation of the central vacuum cleaner, the following is important:

- Carefully read the complete manual before starting assembly!
- Observe the applicable safety instructions regarding fire, working on electricity and buildings!
- Always use the correct tools!
- Replace defective parts only with original spares. If you do not do this, the safe and proper operation of the door can not be guaranteed! In such a case the guarantee becomes void!
- The components that are used are made of high quality, durable and solid materials. However, these components must be mounted with great care to avoid them from damaging.
- Failure to follow these instructions can result in serious injury or material damage.
- When having finished the installation, make sure that this instruction and assembly manual is given to the end-user.
- This machine is not meant to be used by children nor by people with a mental illness, unless they have been informed about the use and the dangers.

2. TECHNICAL DATA SHEET

general data

- Remote control 12V-DC with safety transfo acc.: VDE0551
- EMF-Printed circuit (compulsory since 1/1/1996)
- Motors 220-250V, 50Hz, insulation class E (acc. IEC publication '85)
- To install, only in dry rooms
- Finishing :
Millennium : in PC/ABS

WHEN STIPULATING
ENGINE TYPE TAKE
INTO ACCOUNT
ALTITUDE ABOVE SEA
LEVEL

millennium

TYPE	MI 1251	MI 1411	MI 1451	MI 1511	MI 2411	MI 2001
Motor 230V	Through Flow	By-Pass	By-Pass	By-Pass	By-Pass	By-Pass
Primary filter	Paper filter Brano	Cyclonic	Cyclonic	Cyclonic	Cyclonic	Cyclonic
Secondary filter	Foam filter	Textil filter	Textil filter	Textil filter	Textil filter	Textil filter
Nom. power	1400 W	1200 W	1200 W	1200 W	1750 W	1200 W
Max. Power	1610 W	1560 W	1355 W	1536 W	1850 W	1450 W
Max. durent	6.5 A	6.0 A	5.4 A	7.0 A	8.5 A	5.5 A
Base motor	139 mm	145 mm	145 mm	145 mm	145 mm	183 mm
Turbine	1 stage	3 stages	3 stages	3 stages	3 stages	3 stages
Neg. pressure	3020 mmH ₂ O	2733 mmH ₂ O	2964 mmH ₂ O	3482 mmH ₂ O	3651 mmH ₂ O	3289 mmH ₂ O
Max. Air flow	51,6 l/sec	48,1 l/sec	44,2 l/sec	44,7 l/sec	52,7 l/sec	41,9 l/sec
Max. Airwatts	587	380	348	448	627	372
Dia. air outlet	Intern	50 mm	50 mm	50 mm	50 mm	50 mm
Cap. dust container	18 l	18 l	18 l	18 l	18 l	18 l
Number of sockets :	5	7	8	10	15	12
(indicatives values)						
Max. distance	20 m	20 m	25 m	35 m	50 m	35 m
Dimensions (m)	0,38 × 1,00 × 0,40	0,38 × 1,00 × 0,40	0,38 × 1,00 × 0,40	0,38 × 1,00 × 0,40	0,38 × 1,00 × 0,40	0,38 × 1,00 × 0,40
Installed dimensions (m)	0,75 × 1,40 × 0,75	0,75 × 1,40 × 0,75	0,75 × 1,40 × 0,75	0,75 × 1,40 × 0,75	0,75 × 1,40 × 0,75	0,75 × 1,40 × 0,75

3. MOUNTING

millennium

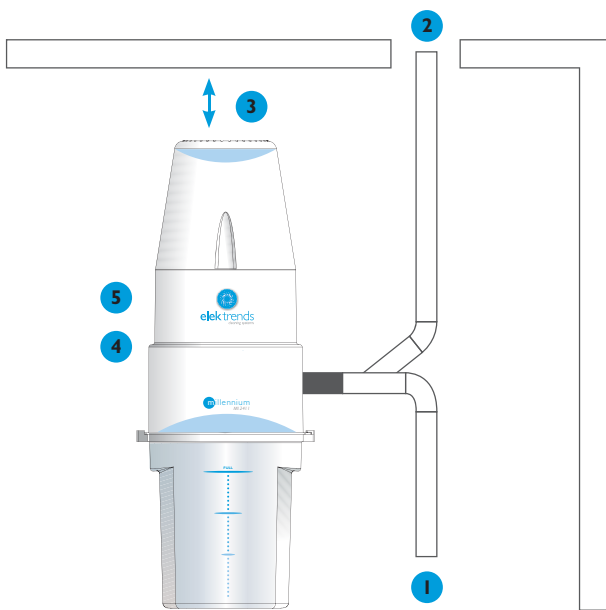

MI 1251

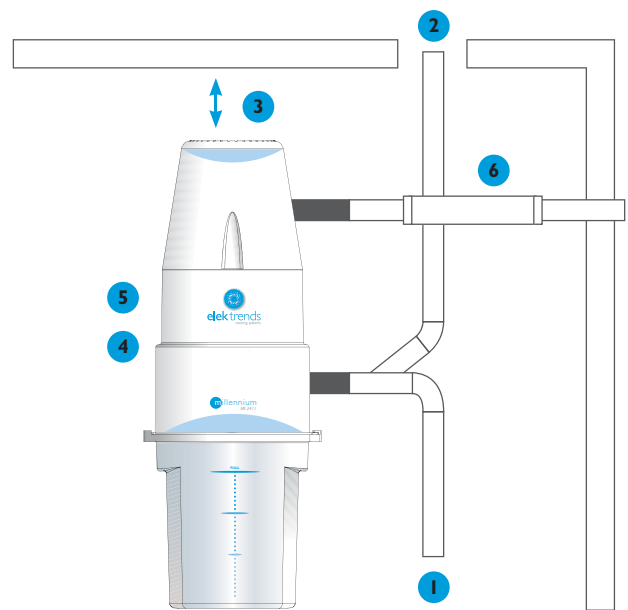

MI 1411 / MI 1451 / MI 1511 / MI 2411 / MI 2001

1. Suction conduit pipes for basement & ground floor
 2. Suction conduit pipes for floors
 3. Min. distance of 30cm to the ceiling
 4. 12V wire connection unit
 5. Power cord connection unit
 6. Silencer
-
- a. Motor cover
 - b. Motor
 - c. Filter housing
 - d. Textile filter
 - e. Dust container
 - f. Exhaust air outlet
 - g. Air inlet: PVC-tube 50mm or 2"
 - h. Bayonet fixing for bin



4. PLANNING A CENTRAL VACUUM SYSTEM

A. Position of Vacuum unit

This should be sited away from the living areas but remain accessible. Garages and basements are ideal. It needs to be mounted on a wall at a height which allows the dust container to be removed easily. For preference, the vacuum unit should be fitted at the lowest convenient point. Ideally, it should be installed so that the vacuum unit is less than 3m above the lowest point in the system. It should not be installed where it is damp or where it can get wet. The ambient temperature should be preferably not exceed 30°C and the area where the unit is sited should be ventilated.

Some of the smaller models M11251/Premium—have through flow motors, which means that the air sucked in by the vacuum fan is exhausted to atmosphere through the motor in order to cool it. All the other models have by-pass motors, meaning that there is a separate cooling fan on the motor and that the air from the vacuum fan is vented to atmosphere through an exhaust pipe. Apart from the smaller models, all units need to be vented outside the building. Allow enough space for a silencer if required—a silencer is approximately 30cm long. When stipulating engine type take into account altitude above sea level. The technical data in the table have been based on 10m above the sea level. By 100 meters above this altitude 10mBar uplift must be added (1000 mm/Ws correspond to 100mbar suction power)

B. Position of vacuum sockets

The general rule is to site these centrally within a building in order that as much floor area can be covered with the minimum number of sockets. It is not necessary to install a socket in each room—position the sockets so as to cover as large an area as possible. If using a 7.5m hose, each socket can provide approximately 50 to 60m² cover; while a 10m hose will cover 70 to 80m². In an existing building, real distances can be measured, but if planning a new installation from drawings, it will be necessary to use a scale rule to determine where to site the sockets. When planning from drawings, keep in mind that a hose will have to go around furniture and other obstructions which do not yet exist. It may not be so easy to put them in the ideal position. As they are inexpensive and easy to install, it is better to put in two sockets in less than ideal positions rather than struggle to install one socket in the perfect position. The sockets can be installed either in the walls or the floor.

C. Planning the pipe system

Ideally this should be as short as possible. The position of the sockets will probably be determined by how easy it is to get the pipework to the position selected for the sockets. The choice will probably depend on the construction of the building. The pipe work connecting sockets to vacuum sockets is best run through the building's natural voids: for example, under the floor, inside stud walls and in the space between ground floor ceiling and the first floor.

If it is difficult to design a network of piping which allows the sockets to be put in the optimum position by using the floor voids, then the solution may be to take the main run of pipe directly into the roof space and run the pipes down to individual sockets from there. The following page illustrates some of the possible arrangements for installing vacuum sockets in walls. The same principles apply when installing vacuum sockets in the floor. Both PVC "Millennium" or a stainless steel "Design" socket can be used for wall installation. However for floor installation, only the "Design" range is recommended.

Ideally vacuum sockets are installed in stud walls, so that the pipe connected to the socket runs within the wall. See diagram on left. These fittings have a fitted depth of between 75 & 90mm. If the fitting is deeper in the wall, an extension piece can be used between the socket & any Millennium fitting if the fitting is set too far back into the wall. It extends the spigot to an extra 25mm.

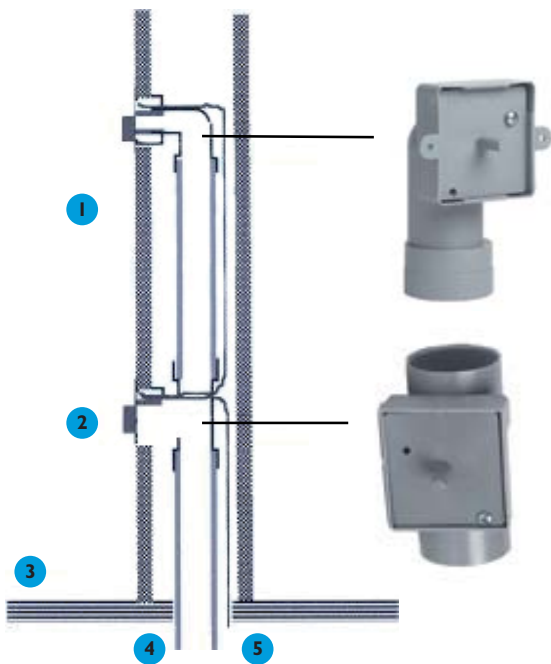

Millennium 90° elbow fitting (sharp bed) with plasterguard fitted.

1. Stud wall
2. Vacuum socket
3. Floor
4. 50mm pipe inside stud wall
5. Low voltage cable attached to pipe
6. Millennium extension piece

If the wall is solid, leave (or make) a channel in the brickwork in order to accommodate this arrangement-see diagram on right.

1. Solid wall
2. Vacuum socket
3. 50mm pipe inside wall
4. low voltage cable attached to pipe
5. Floor

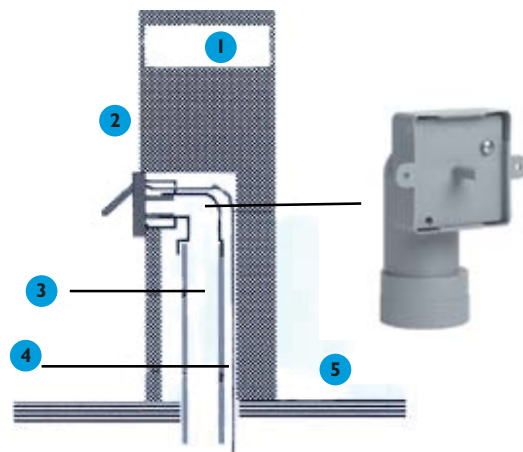

Sometimes, it is not possible to run the pipe within the wall as shown in the above diagrams. In this instance, use a Millennium straight fitting connected to a straight piece of pipe running through to the back of the wall. Two other arrangements are shown below using a separate sharp 90° knuckle bend, which should be fitted as close to the vacuum socket as possible.) This is important as it is this bend which will prevent long thin objects from entering the system and possibly causing a blockage. If an object does get stuck in this bend, one must be able to retrieve it from the vacuum socket.

Pipe chased into rear of wall with separate 90° bend

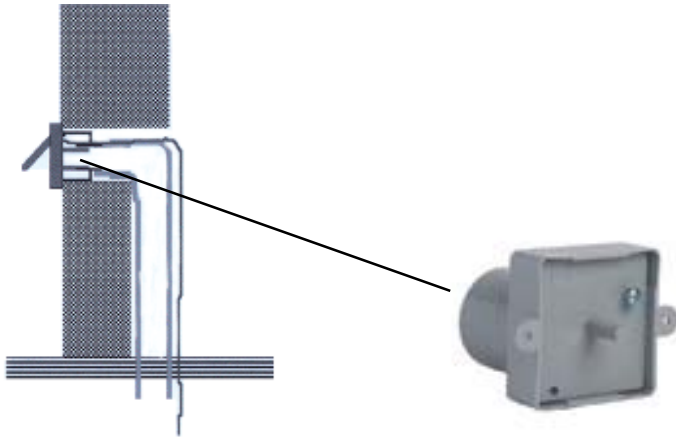

Millennium straight fitting with plasterguard fitted

D. Example diagram showing where to fit vacuum sockets

This represents a house with a total floor area of approximately 400m². It is a 6 bedroom house with generously proportioned rooms. The ground floor covers approximately 150m² plus a garage of 45m² making a total of about 200m². There is the same floor area upstairs.

By placing the inlet sockets strategically, 2 sockets can provide cover for the ground floor of the house using a 10m flexible hose. This is shown by the lines with arrowheads on the drawing. A utility socket can be fitted near to the garage entrance so that the vacuum hose can be used to clean cars inside and outside the garage.

The first floor can be served by 2 sockets on the landing directly above the 2 sockets in the hall. The room over the garage would be covered by a socket on the first floor directly above the vacuum unit.

This house would need a total 6 vacuum sockets—5 built-in sockets & one utility socket.

If a shorter (7,5m) flexible hose were to be used, then an extra socket would be required on each floor and the vacuum sockets would need to be re-sited.

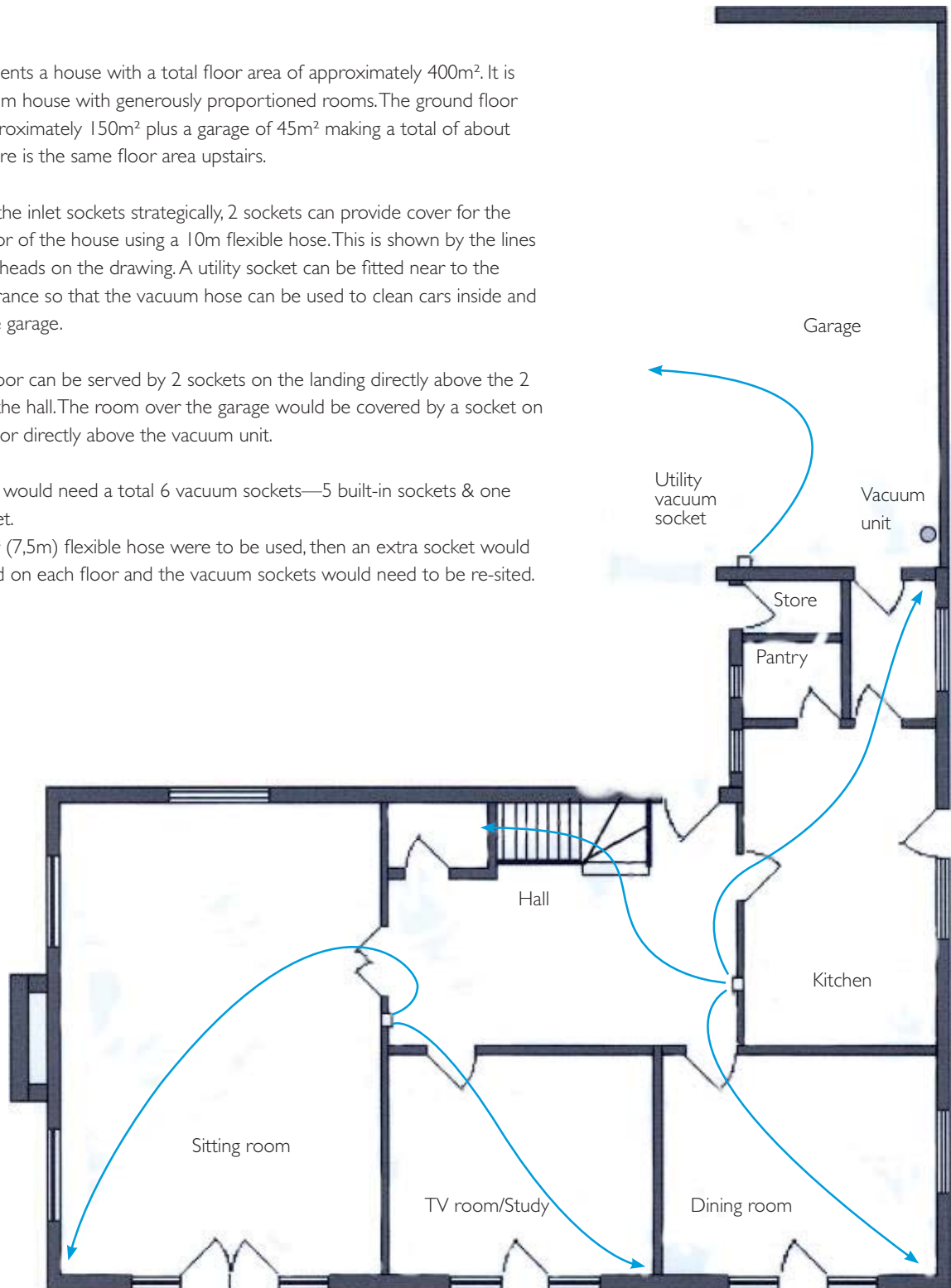

E. Understanding

The principle of a central vacuum system is as important as understanding the mechanics of the installation.

Following these guidelines should ensure that the installation is easily accomplished and that the pipework will not become blocked in use.

F. The principles

The system is designed so that it will not become blocked in normal domestic use. The narrowest part is the point at which items are sucked into the system, this being the brush or tool on the end of the hand-held wand. The diameter of the tubing gets progressively larger so that if an item can pass through the suction tool, then it will pass through the rest of the system. The internal pipe diameter of a suction hose is 32mm, it increases to 43mm at the 90° elbow and again to an I.D. of 46mm for the main run of pipe. If an item is small enough to pass through the 32mm pipe, then it will pass through the 43mm bend and the 50mm pipe easily.

It is possible to suck a long thin item, such as a pencil, into the vacuum system. This could pass through all the pipework until it reached a bend where it could become stuck and cause a blockage. However this is prevented by the use of a sharp right-angle bend behind the vacuum socket. As the pipe immediately after the bend is larger than the socket's internal diameter and all subsequent bends are 45° bends or swept 90° bends, then anything that can pass through this sharp 90° bend will pass unhindered through the rest of the system. If a pencil is sucked into the system, it will become lodged in the sharp 90° bend (elbow fitting) behind each socket and can be removed through the vacuum socket.

G. The pipework

Imagine the pipework as a simple tree with the longest run of pipework as the trunk, the shorter runs as branches and the vacuum unit as the root. The trunk & branches may need to have a few bends in them in order to fit the building and, as with most trees, the branches join the trunk at an angle pointing in the direction of the roots. In a central vacuum system, the branches of the pipework must join the main run at an angle using a swept 90° tee or 45° tee (see diagrams)

H. The pipe fittings

It is important to use the correct fittings for the pipework. Apart from the 90° bend fitted directly behind each socket, all bends should be curved or "swept" bends. This also applies to Tee connections. (see diagrams of permissible connections). Use two 45° bends to make a swept 90° bend and a 45° Tee with a 45° bend to make a swept 90° Tee. In order that this is clear, some pictures of suitable fittings are included.

Bend 45°
M/M



Bend 45°
M/F



Straight connector



45° Tee Connector



Do not use this type of bend in the general run of pipework

Use only with a vacuum socket



I .The pipework

This is 50mm (outside) diameter and is normally supplied with the vacuum unit. When installing pipework, start at the vacuum socket and work back to the vacuum unit. Initially fit the components together without glue to make sure all the parts fit properly as the solvent glue dries very quickly, and once set, the components will not come apart. It will aid the efficiency of the system if the inside of the pipe is as smooth as possible. This can be achieved by making sure that all cuts to the pipe are square and rough edges removed with a fine file or sand paper. The pipes should be pushed firmly into any connector so that the end of the pipe butts up against the lip inside the connector.

It is most important : that the solvent glue is applied to the outside of the pipe (or the male part of any fitting) when making a connection. This is so that any excess glue is squeezed out of the joint to the outside of the pipe where it is harmless. Avoid excess glue on the inside of the pipe. Before applying glue to a joint, make sure that both surfaces are clean and free from grease. If necessary wipe both surfaces with a clean cloth and solvent such as acetone (nail varnish remover). Apply adequate glue to male side of the joint and insert into female side, twisting the 2 parts as you do so in order ensure that the glue is evenly spread and a sound joint is formed. Where this is difficult to achieve due to restricted access, fit the items without glue, make a mark across the joint(s), remove items and glue together with the marks aligned. Components can then be fitted as an assembly. For maximum efficiency, it is important that there are no leaks in the system.

J. The electrical supply

The vacuum unit is permanently connected to the mains electricity. All domestic models can be run from a normal electrical socket. Each vacuum unit has an internal transformer which provides 12V to a pair of terminals at the rear of the vacuum unit. These are connected to a pair of contacts on the back of each vacuum socket using bell wire or speaker cable ($2 \times 0,75\text{mm}^2$ side by side). The 12V connections to the sockets should be in parallel. It is not necessary to run a cable from each socket back to the vacuum unit or from one socket to the next. The cable from each socket can follow the pipe and two cables can be joined with a connector wherever a run of pipe joins another, so that there is only one pair of wires going back to the vacuum socket.

Important—Commissioning When the pipework and wire have been installed, check the continuity of the wiring. At each socket, make sure that the 2 ends of the wire are not touching & check the circuit by putting an ohmmeter across the 2 ends of the cable at the vacuum unit end. It should be an open circuit. Now test the wiring to each socket in turn by twisting the 2 ends of the wire together at the socket end.

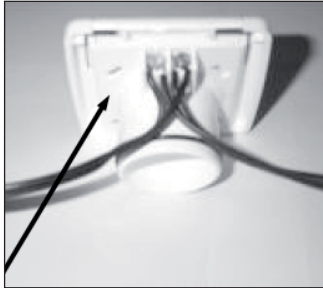

Rear of a socket showing 12V parallel connections

Note:

If the O'ring on the back of the vacuum socket made wet, it is much easier to fit (or remove if necessary)

Only test one socket at time Check the circuit again at the vacuum unit end-it should be a closed circuit. Separate the 2 ends of the wire at the first socket before testing the second. Repeat for each socket.

When the end of the flexible suction hose is inserted into the vacuum socket, the circuit is completed and a 12 volt signal is sent to the vacuum unit.The vacuum unit starts and will run until the flexible hose is removed from the socket. (There is an option to have a switch in the handle of the flexible hose which allows the vacuum unit to be switched on and off without removing the hose from the socket.)

The cable from the 12 Volt terminals connect to each of the sockets in parallel. It can be attached to the pipework using cable ties or tape. If buried in the wall or floor; it should be protected by conduit .

Drill out of the holes on the back off the box of the socket fitting & put low voltage cable through for connection to terminals on back of socket

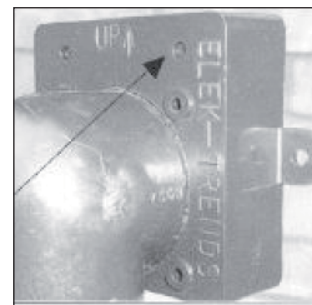

A 90° socket fitting with signal cable fitted. Pass cable through a hole drilled in the rear of 90° socket fitting.Tie a knot in the cable to stop it falling back and feed the excess wire back down the pipe ready for connection to terminals on rear of socket after walls have been plastered / plaster boarded. Re-fit plasterguard if necessary.The front face of the box should be fitted to the front face of the studwork—the level with the rear of the plasterguard.The level with the rear of the plasterguard.The spigot on the rear of the socket has maximum 20mm reach so can be fitted through 12.5mm plasterboard into the hole in the socket fitting.

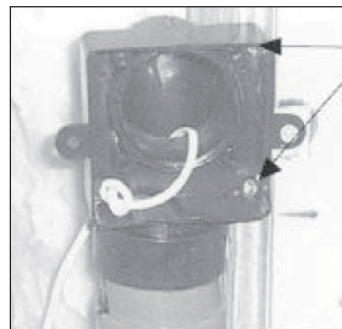

NB
Secure box to studwork with 2 screws though the side of the box.

The same principle applies to fitting a socket box in a solid wall. The front face of the box can be anywhere from being flush with the finished surface (usually plaster) to 20mm behind the finished surface, although fitting sockets is easier if the box is somewhere between 5 & 15mm beneath the finished surface. Secure box to wall. A screw through the back of the box will do as well as a generous squirt of Gripfill or similar fixative. Don't screw the screws of the vacuum sockets to deep.

Make pipe connections like these for pipes which join in either the horizontal or vertical plane. Airflow must always follow the sweep of a bend.

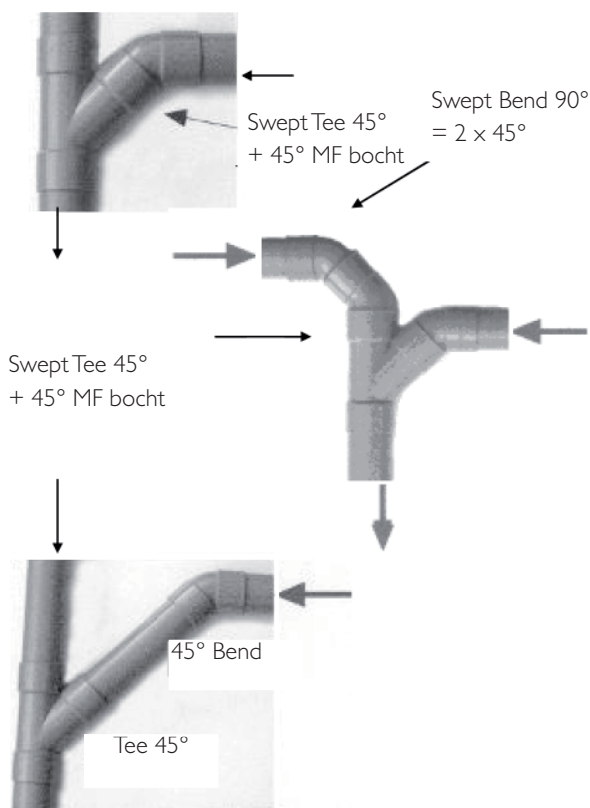

If there is a pipe joining the main pipe from below, a connection like this is necessary.

Do not connect the vertical pipe directly to the horizontal pipe from below.

Use a Tee connector with either a 45° or swept 90° bend so that connection is coming in from the side –i.e. horizontally in the same plane as the main pipe. Then fit a swept 90° bend to the stem of the Tee to connect to the vertical pipe.

If a vertical connection is made directly into the horizontal pipe from below, it is possible for heavy objects to fall into the vertical pipe and possibly cause a blockage.

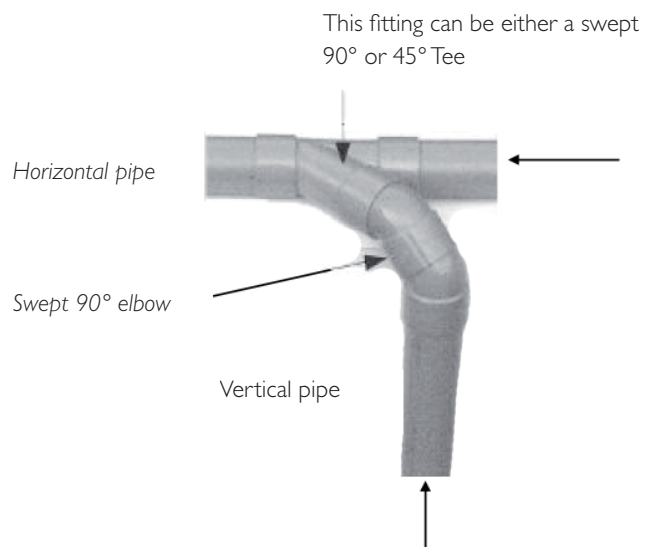

Do not accept the pipework as shown below !

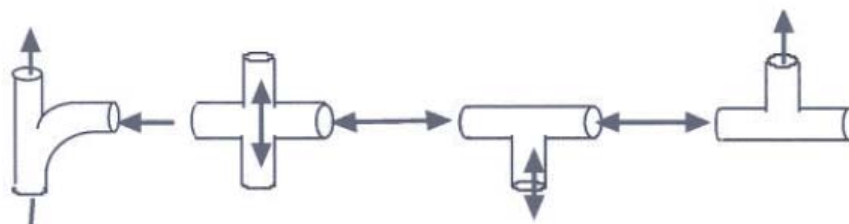

K. Millennium range of PVC vacuum sockets

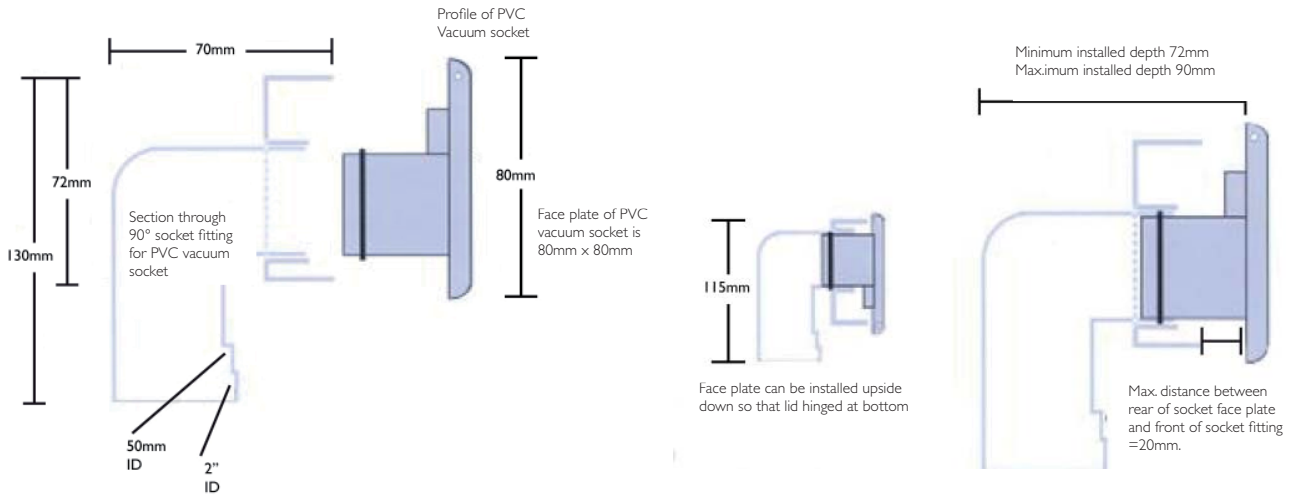

L. Designer range of stainless steel vacuum sockets

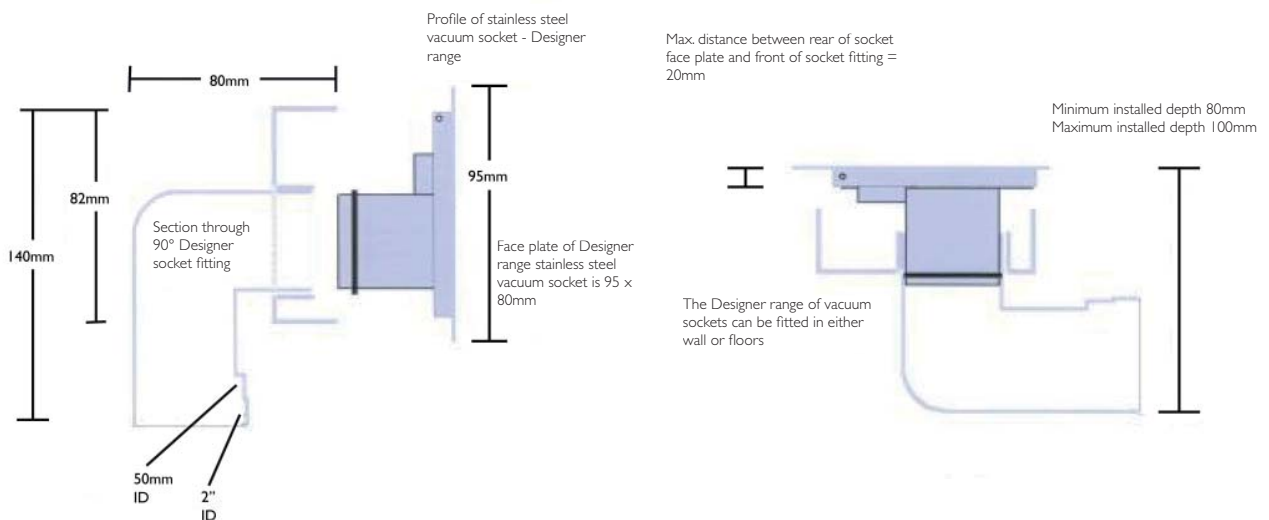

M. Installation materials



45° F/F
elbow



45° F/F
elbow



45° Tee



50mm Straight
connector



PVC-pipe
50 x 1,8mm



50 mm pipe clip



Exhaust grid



Elbow fitting 90°



Straight fitting



90°M/F elbow for use
straight fitting only



Tee fitting



Utility elbow socket



Utility tee socket



Silencer



Heavy duty flexible hose
for use underground

5. GENERAL NOTES

Vacuum sockets



It is conventional for vacuum sockets to be fitted so that the cover opens upwards—i.e. it is hinged at the top of the socket. For this reason the socket fittings (boxes) are marked with an arrow and 'UP' to show the correct way to fit them. However, it is easier to insert the end of the hose into a vacuum socket if it opens downwards (picture above) so that the hole in the socket is exposed as the flap starts to open. If this arrangement is required, then the fittings must be installed with the arrow and 'UP' at the bottom, not the top, of the fitting. When using the 90° elbow fitting, rotate the box on the end of the tube, if necessary (picture above right).

Internal pipe work

It is important to note (and preferably mark) the route of the pipe through the building when it is not obvious that there is a pipe under the floor or in a wall. This is especially important during construction as not all artisans will be familiar with a central vacuum system and may inadvertently damage the pipework. A nail through the pipe will soon cause a blockage and fractured pipe will lead to a loss of suction.

External pipe work

It is assumed that the pipework will be run within a building, but sometimes it is necessary to run a pipe outside—to a detached garage, for example. In this case, it is important that the pipe be insulated from extreme cold in order to prevent condensation in the pipe, although short runs of unprotected pipe should not be a problem. If it is necessary to run a pipe to another building, the rigid PVC should be buried at least 50cm deep and protected, preferably by putting it inside a larger diameter pipe. This not only gives a degree of insulation, but also provides some protection against ground movement. Alternatively, a reinforced heavy duty flexible hose can be used underground. Whilst this hose is more costly, it is a lot easier & quicker to lay. Ensure all joints are glued well and that there is no opportunity for ingress of water to the system. If a pipe runs outside a building in a position where it can get very cold, it should be lagged and boxed (or run inside a larger pipe).

And Finally

Having installed a vacuum system in a new house, many people are tempted to take advantage of its impressive performance to clean up the site. Please be aware that cement and plaster dust will stick to the heavy duty textile filter inside the vacuum unit and cause a loss of performance. This can be overcome by removing the dust bin from the unit and shaking the filter vigorously (see directions for use in the unit), and if necessary, removing the filter from the canister.

Alternatively, do not use the Central Vacuum Cleaner for cleaning a building site!

6. USE AND MAINTENANCE

Place the hose and tool rack on the wall at eye level.

Place the hose in a few big circles round the hose and tool rack; there is also place for the suction mouths.

Choose the right suction mouth for every work.

- For smooth floors and parquet : the long brush with hairs (1.0300.1001)
- For carpet : the adjustable carpet tool with hairs drawn in so the metal level pushes against the carpet. (1.0300.1000)
- For furniture and rough levels : the circular dusting brush (1.0300.1005)
- For seats and the car : the upholstery tool (1.0300.1003)
- For corners and crevices : the crevice tool, which increases the suction power due to it's little opening. (1.0300.1004)
- Link up the two chromed extension tubes (1.0310.1000) with the grip (1.0210.1001) to clean the soil.
- Lay the hose always open before getting started, short bends obstacle the air speed and the suction capacity.
- Empty the dustbin of the central vacuum cleaner regularly.
Look the first time after about 1 month, in this way you'll know in the future how many times you have to empty it in one year.
- When the suction power decreases, empty the dustbin and clean the filter according to the type of unit (see directions for use on the unit)
 - With some of the units the foam filter is pulled around a carton filter system. The carton filter has to be, before mounting the foam filter, beaten outside very well to clear.
 - With the filtersystem with paper bag is also a foam foreseen. There is no spare one, because it normally doesn't get dirty. Only when the paper bag thorns up; the protection filter must be washed and put back.
 - For the units with a textile filter; one can beat the textile filter to remove the fine dust parts after emptying the dustbin.
- When the automatic fuse switches of regularly , notify the installer

7. IMPORTANT SAFETY PRECAUTIONS

NOTE! To reduce the risk of fire, electric shock or injury, read all safety precautions and warning text carefully before using the machine.

- These central vacuum cleaners are solely intended for dry vacuuming indoors.
- Do not vacuum up liquids unless a special wet pick-up separator unit is used.
- Do not vacuum near smoke, naked flames or fire, e.g. cigarettes, matches, hot ash or flammable liquid or gas.
- Do not vacuum in areas where flammable liquids or gases may be present.
- In case of a blockage, the motor should be stopped to avoid overheat.
- Unplug the machine before changing the filter or bag before doing any maintenance work.
- Always unplug the machine by pulling on the plug, not the power cord.
- The wall socket and plug must be positioned so that they are clearly visible.
- Do not vacuum up sharp objects such as broken glass that could puncture the dust bag unless an interceptor kit is used.
- Do not cover the central unit or restrict its intake port.
- Follow the operating instructions carefully. Servicing and repairs should only be carried out by an authorised workshop. Use only parts and accessories recommended by the manufacturer. Never attempt to modify the central vacuum cleaner in any way.
- Do not use the central vacuum unit if the power cord is damaged. The central vacuum cleaner is fitted with a special type of power cord that must be replaced with a cord of the same type if it is damaged. This can be obtained from an authorised service workshop. To avoid danger the power cord should be replaced by an approved Elek Trends engineer.
- The central vacuum cleaner is very powerful and should never be used as a toy by children.
- Never vacuum without a filter dust bag fitted to the machine.
- Warning! The central vacuum cleaner must not be used to clean up hazardous waste.

NOTES

NOTES

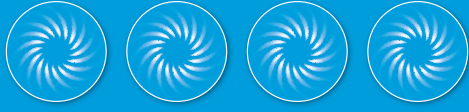



elektrends
cleaning systems

Elek Trends Productions nv
Rue des Bengalis 4 | B - 7700 Moeskroen
Tel. +32 (0)56 48 15 90 | Fax +32 (0)56 48 15 91 | info@elek-trends.be